



**TROFEO
MARCO RIZZOTTI**
INTERNATIONAL
OPTIMIST CLASS
TEAM RACE
VENEZIA



**COMITATO SPORTIVO
TROFEO MARCO RIZZOTTI**

38° TROFEO MARCO RIZZOTTI
INTERNATIONAL OPTIMIST CLASS TEAM RACE
VENICE ITALY MAY 14th – MAY 17th 2026

SAILING INSTRUCTIONS

JURISDICTION AND RACE MANAGEMENT

INTERNATIONAL JURY

| | | | | |
|----|----------------------------|-----------------------------|-------|-----|
| 1 | COSKUNER GENÇ Pinar | CHIEF UMPIRE | IJ/NU | TUR |
| 2 | PEREZ ANDREAS | JURY CHAIRMAN/UMPIRE | IJ/IU | ESP |
| 3 | DAVID MARIA GOSALBEZ | | IJ/IU | ESP |
| 4 | TIMO HASS | | IJ/IU | GER |
| 5 | GREG EATON | | IJ/IU | GBR |
| 6 | EWA SZYFTER | | IJ | POL |
| 7 | KARL PETTER HAUGEN | | IJ | NOR |
| 8 | GIUSEPPE D'AMICO | | IJ/RU | ITA |
| 9 | GIUSEPPE GENTILE | | IJ | ITA |
| 10 | LEONARDO GIANNINI | | NJ/NU | SUI |
| 11 | GIUSEPPE AMBROGIO | | NJ/NU | ITA |
| 12 | ELISA D'IPPOLITO | | NJ/RU | ITA |

RACE COMMITTEE

| | | | | | |
|---|------------------|----------------------|------------|-----|-----|
| 1 | GIANOLI | Claudio | PRO | NRO | ITA |
| 2 | VILLANI | Adolfo (Dodi) | DRO | IRO | ITA |
| 3 | SCARPA | Massimo | | NRO | ITA |
| 4 | MORGANTIN | Matteo | | NRO | ITA |
| 5 | CORRADI | Riccardo | | RRO | ITA |
| 6 | DE RIGO | Gianmaria | | RRO | ITA |
| 7 | LEANDRO | Mattia | | RRO | ITA |
| 8 | FLORA | Luisa | | RRO | ITA |

1 - RULES

- 1.1 The event will be governed by the rules as defined in The Racing Rules of Sailing 2025-2028.
- 1.2 Appendix D – Team Racing Rules will apply and races will be umpired.
- 1.3 The “class rules” for the purposes of the definition of “rules” are the International Optimist Association Class Rules.
- 1.4 Decisions of the Protest Committee will be final as provided in RRS 70.3.
- 1.5 Spare



COMPAGNIA DELLA VELA
Isola di San Giorgio Maggiore n.5
30124 Venezia
T. (+39) 041 5200884
segreteria@compvela.com



DIPORTO VELICO VENEZIANO
Porticciolo E. De Zottis
30132, S. Elena, Venezia
T. (+39) 041 5231927
info@dwv.it

1.6 In case of conflict between the Notice of Race and the Sailing Instructions, the Sailing Instructions will take precedence. This changes RRS 63.5(c).

2 - ELEGIBILITY

- 2.1 To become eligible a team shall register as required by the notice of race or, if not specified, on arrival at the event.
- 2.2 A registered team shall change its members only in exceptional circumstances and only with the permission of the race committee. There will be no right to request redress from any party concerning such changes, this changes RRS 61.1(a) (redress).

3 - NOTICES to COMPETITORS

The official notice board will be on RRS at <https://www.racingrulesofsailing.org/events/13187/>
All official notices, information and results will be also posted and on the official website of the event <https://rizzottisail.it/> and in the notice board located in front of the Regatta Office, located at Centro Sportivo Agonistico Ottavio Ghetti, of the Compagnia della Vela, Lungomare Dante Alighieri 6 Punta Sabbioni (Cavallino–Venezia).

In any case the official notice board remains the one described in these SI and possible differences will not be ground for requesting redress, this changes RRS 61.

4 - CHANGES in SAILING INSTRUCTIONS

- 4.1 Any written changes to the Sailing Instructions or the schedule will be approved by the Principle Race Officer, signalled by flying flag L from the shore signal position and posted immediately after the Participants' Meeting on the day it will take effect. Any change to the schedule requiring racing to begin earlier than scheduled will be posted by 21:00 on the day before the scheduled change takes effect and will be posted on the Official Notice Board.
- 4.2 Any oral changes to the sailing instructions on the water will be signalled with the display of the third substitute and communicated to each team by the Race Committee and/or umpires, and will be effective immediately. These changes will also be communicated to coaches on a VHF channel 17 and posted on the official notice board at the end of that day's racing.

5 - SIGNALS MADE ASHORE

- 5.1 Signals made ashore will be displayed on the flag pole located close to the Regatta Office.
- 5.2 When AP is displayed ashore, "1 minute" is replaced with "not less than 30 minutes" in the race signal AP. This changes RRS race signal AP.

6 - EVENT SCHEDULE

| Day | Date | Time | Description |
|-----|--------|--------------|---------------------------------|
| 1 | 14 may | 15:00-20:00 | On-site registration |
| | | 19:00 | Coaches Briefing (Mandatory) |
| 2 | 15 may | 09:00 | Briefing (Mandatory) |
| | | 11:00 | First Warning Signal |
| | | after racing | Umpires and Competitors debrief |
| 3 | 16 may | 09:00 | Briefing (Mandatory) |
| | | 11:00 | First Warning Signal |
| | | after racing | Umpires and Competitors debrief |
| 4 | 17 may | 09:00 | Briefing (Mandatory) |
| | | 11:00 | First Warning Signal |
| | | 16:30 | Last Warning Signal |
| | | after racing | Umpires and Competitors debrief |
| | | 19.00 | Awards ceremony |

7 - FORMAT

- 7.1 The event will be a four boat against four boat team race. For teams having five competitors, any four may compete in a race, so long as the fifth competitor remains in the area designated for coaches from the warning signal of that race until that race has been completed.
- 7.2 The format of the event is a Round Robin (RR) series where every team sails other teams according to the posted schedule.
The format of the event may be changed during the event by the Principal Race Officer in conjunction with the Chief Umpire and the Jury Chairman in an even way after considering the number of entries, the weather conditions, the sailable time available and other relevant factors.
Rizzotti Trophy will be awarded whatever will be the number of sailed races. This changes RRS D4.3(b).
- 7.3 In the event that the round robin is completed a further format may be sailed as communicated per SI 4.
- 7.4 The schedule of races will be displayed on the official notice board. Any changes thereto and schedules for subsequent rounds will be displayed not less than 10 minutes before the start of that phase of the competition.
- 7.5 Every race will be assigned a race number in the race schedule. The schedule of races will be given to each team at least 60 minutes before starting racing.
- 7.6 The race committee may at any time remove a particular race from the published sequence of races and run it at a later time.
- 7.7 Each team shall be assigned letters for the team and numbers for the boat, which shall not be reduced in size in any dimension and shall be securely attached to the stern and to the first 20% of the forward part of each side of the hull, as stated in Appendix A to these Sailing Instructions.
- 7.8 On the last racing day, there will be three possibilities:
- If by 14:30 the RR is complete, go to Semifinals with 1st vs 4th and 2nd vs 3rd (the winner is the first that have 2 points) and Finals for 1st and 2nd place (the winner will be the first

who have 3 points) and Petit Finals for 3rd and 4th place (the winner will be the first who have 2 points).

- b) If at 14:30 the RR is not complete, carry on sailing the RR. If RR will be completed before 15:30, Semifinals will not take place, only Finals will be sailed first vs second (the winner will be the first who have 2 points). If the RR will not be completed before 16:30, positions will be as % win.
- c) If Semifinals and/or Finals are started but not completed before 16:30, teams should be ranked according to the RR position (changes RRS D4.5).

8 - COURSES and CHANGE of COURSE

- 8.1 The course located in front of the beach of the Camping Marina di Venezia, Cavallino - Venice, will be identified by a YELLOW flag with 'RC' in green letters displayed on the signal boat.
- 8.2 The course shall be as in the diagram in Appendix B to these sailing instructions. After finishing when returning to the waiting area all boats shall leave the finish boat and marks 4 and 3 to starboard at a minimum distance of 50 meters and shall not interfere with boats racing.
- 8.3 The Race Committee may move marks of the course. RRS 33 will not apply. The moving of a mark by the Race Committee will not be grounds for a boat to request redress. This changes RRS 61.1(a).
- 8.4 Courses will not be shortened. This changes RRS 32.
- 8.5 The Race Committee will set the course length in order to race for about 8 minutes. A different duration of the race will not be grounds for a request for redress from a team or a boat. This changes RRS 61.1(a).
- 8.6 Unless otherwise specified in the appendix to these SIs, the time limit for each race will be 20 minutes. Boats failing to finish within five minutes after the first boat finishes will be scored DNF. This changes RRS 35.

9 - MARKS

Marks will be as follows:

| Course Marks 1, 2, 3, 4 | Starting Pin End Mark | Finishing Mark |
|-------------------------|-------------------------|-------------------------|
| Yellow inflatable | Red cylinder inflatable | Red cylinder inflatable |

- 9.1 The starting line shall be between the staff with an orange flag on the Race Committee Start boat and the pin-end mark described above at the other end of the line.
- 9.2 The finishing line shall be between the staff with a blue flag on the Race Committee Finish boat and the inflatable mark described above.
- 9.3 Inflatable white buoys delimited the waiting area.

10 - THE START

10.1 Rule 26 (starting system) and related Race Signals is so modified:

| Signal | Min. to start | Sound signal | Visual signals |
|-------------|---------------|--------------|---------------------------|
| Warning | 3 | One | Trofeo Rizzotti Flag UP |
| Preparatory | 2 | One | Code flag P UP |
| One-minute | 1 | One | Code flag P DOWN |
| Start | 0 | One | Trofeo Rizzotti Flag DOWN |

Note: The warning signal of the following match may be displayed together with the starting signal of the previous match or later.

10.2 Failure to hear a signal shall not be grounds for a boat to request redress. This changes RRS 61.1(a).

10.3 The race number will be displayed on the leeward side of the committee boat before the warning signal. When the race number is displayed in this way it overrides all prior communications, schedules or instructions.

Attention may be drawn to an imminent warning signal by a series of short sound signals.

11 - RECALLS

11.1 When a boat is subject to RRS 29.1 flag X need not be displayed for more than 1 minute after the starting signal; this changes RRS 29.1.

11.2 spare

11.3 A boat that fails to start within two minutes of her starting signal will be scored DNS without a hearing. However, if the boat was OCS at her starting signal and did not return to start properly she shall be scored in accordance with rule D3.1(b) without a hearing. This changes RSS A4, A5.1 and A5.2.

11.4 After a general recall succeeding races may be delayed for the recalled race. Attention is drawn to SI 10.3.

12 - PROTESTS AND PENALTIES

12.1 Protests and requests for redress for incidents afloat shall be delivered to the finishing boat within 3 minutes from the end of the race.

12.2 The protest committee may refuse to hear a protest or request for redress unless its outcome is relevant to progress, but not seeding, in the next round of the competition. This changes RRS 60.5(a) and RRS 61.4(a).

12.3 Spare

12.4 Spare

12.5 When a protest committee decides that a breach of a rule has had no significant effect on the outcome of a race, it may make any arrangement it decides is equitable, which may be to order a re-sail or to impose no penalty. This changes RRS D3.1.

12.6 Spare

12.7 Measurement protest can be lodged only by the Race Committee, the International Jury or the Technical Committee. This changes RRS 60.1.

13 - SCORING

- 13.1 RRS D3 shall apply.
- 13.2 Spare
- 13.3 Spare

14 - UMPIRE BOATS

The umpire boats shall fly a black flag with yellow letter "U".

15 - COACH BOATS

- 15.1 Each team is allowed one designated coach boat, and each coach is required to carry a working VHF radio, a suitable anchor and an anchor line sufficient to anchor safely in the designated waiting area.
- 15.2 Coach and spectator boats shall remain anchored in the waiting area designated on the course diagram, unless otherwise directed by the Race Committee and/or Umpires for safety purposes.
- 15.3 Coach boats must expose a white flag with blue letter T, to collect at Race Office.

16 - SAFETY

- 16.1 Each competitor must wear a personal flotation device (PFD), properly secured at all times, with a whistle attached, from dock to dock except when temporarily adding or removing clothing. Wet suits, dry suits and inflatable PFD's do not constitute adequate personal buoyancy. Failure to wear one while racing may result in penalty points added to the boat's score at the discretion of the protest committee.
- 16.2 A competitor retiring from a race shall notify a race committee or safety boat before leaving the course area and notify the race committee immediately upon returning to shore.

17 - PRIZES

Prizes will be awarded in accordance with the Notice of Race.

18 - DISCLAIMER of LIABILITY, INSURANCE

- 18.1 A boat is entirely responsible for her own safety, whether afloat or ashore, and nothing, whether in the Notice of Race or Sailing Instructions or anywhere else, reduces this responsibility.
- 18.2 It is for the boat to decide whether she is fit to sail in the conditions in which she will find herself. By launching or going to sea, the boat confirms that she is fit for those conditions and that her crew is competent to sail and compete in them.
- 18.3 When the boats are provided by the competitors, the boat is required to hold adequate insurance and in particular to hold insurance against third party claims as required by the notice of race or, if not specified, in the sum of at least 1,500,000 Euros.
- 18.4 Nothing done by the organizers can reduce the responsibility of the boat nor will it make the organizers responsible for any loss, damage, death or personal injury, however it may have occurred, as a result of the boat taking part in the racing. The organizers encompass

everyone helping to run the race and the event, and include the organizing authority, the race committee, the race officer, umpires, patrol boats and beach-masters.

18.5 The provision of security boats does not relieve the boat of her responsibilities

APPENDIX “A”

Identification badges, both for the teams (letters) and for the single competitor (numbers) shall be stuck on the starboard and port sides and on transom as shown in the diagram.

The stickers of the sponsors shall be stuck on both sides of the hull, in accordance with Regulation 20 - WS_ Advertising Code.

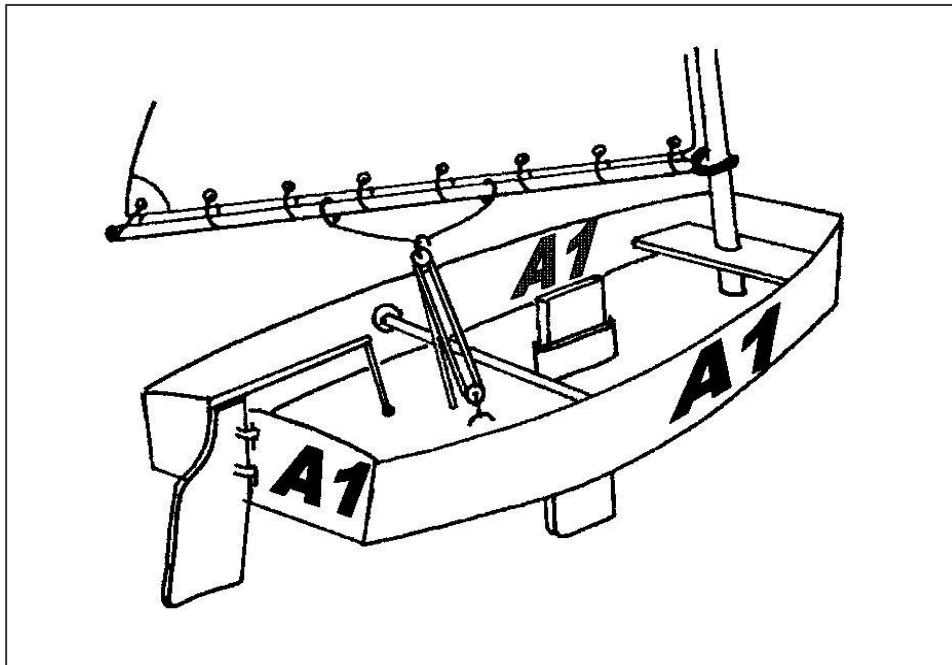

APPENDIX "B"

Diagram and Description of the Course

Copy of TSS software registered to Dodi VILLANI

